

Important Note

FIREFOX

■ Please read the manual to learn the function of the this product before operation.

Damage to the product and potential personal injury may occur if you make an operational error.

This is a RC helicopter, not a toy. You should not only have a prudent operation, but also to have an operational basis. All children using it should be under adult supervision.

The manual includes safety, operation and maintenance. In order to avoid causing damage or serious injury, please obey the instructions and warnings before you using this product.

Additional Safety Precautions And Warnings

FIREFOX

- 1.Recommended age of users: Not suitable for children under 14 years old.
- 2.Operate it in an open space, away from the traffic and people.
- 3.Obey the instructions and warnings, includes the use of optional equipment.
- 4.It has to stay away from chemicals. Small parts and electric equipment must be out of the reach of children.
- 5.Keep away from water because this product has no waterproof function.
- 6.Do not put any parts in the mouth, it will cause injury or death.
- 7.Don't operate the model if the transmitter's battery is in low voltage.
- 8.Don't view the beam of the light emitting diodes, it would effect the eyesight.
- 9.The motor and electric equipment will be heat after flight. Please do not touch them to avoid scald.
- 10.In order to avoid causing damage, please do not touch the high-speed.

重要说明

火狐

■ 操作前，请阅读整个说明书以便了解该产品的功能。未能正确地操作本产品可能会导致产品损坏，对人身财产造成严重损害。这是一个的模型产品，而不是一玩具。 不仅要谨慎操作，还需要具备操作常识和操作基础。若未能安全使用该产品，会毁坏该产品或者对人身，或者对其他财产造成损失。本产品不供没有成人监督下的儿童直接使用。本手册内容包括安全、操作、维护。因此，在装配，安装或使用产品前。我们必须阅读并遵守本手册中所有的提示和警告,以便正确操作,避免造成损伤或严重伤害。

附加安全措施防范和警告

火狐

1. 年龄建议：不适合14岁以下的儿童，这不是一个玩具。
2. 始终在开放的空间操作你的模型，远离车辆、交通和人。
3. 必须仔细地遵循操作说明和警告，包括可选设备的使用方法。（充电器，可选充电电池等）
4. 始终保持远距离所有的化学品，细小部件跟用电设备需远离儿童接触。
5. 应避免与水接触，尤其此设备的设计不具备防水功能；水汽也会导致电子产品损害。
6. 切勿将模型的任何部件放在嘴里，因为它可能会导致严重受伤甚至死亡。
7. 当遥控器电池电压过低的时切勿操作你的模型。
8. 请勿直视发光二极管的光束，以免影响眼睛。
9. 飞行器在飞行中和飞行后，马达及电子元件会产生高温，请勿触摸，以免发生烫伤危险。
10. 请勿触碰高速旋转的螺旋桨，以免造成损伤。



Note: Using the original factory USB charger can ensure charging safety. Suggest you use the original factory USB charger part, other chargers may cause battery damage and property damage.

Warnings! The battery will fire, explode or leak if not strictly observing this item described below. :

1. Do not immerse the battery in water or seawater, and keep the battery in a cool dry environment during stands by period.
2. Keep all batteries out of the reach of little children. Consult a doctor immediately if a battery is swallowed.
3. Do not use or leave the battery near a heat source such as fire or heater.
4. Use the battery charger specifically for that purpose when recharging.
5. Do not reverse the positive (+) and negative (-) terminals.
6. Do not connect the battery to an electrical outlet.
7. Do not dispose the battery in fire or heat.
8. Do not short-circuit the battery by directly connecting the positive (+) and negative (-) terminals with metal objects such as wire.
9. Do not transport or store the battery together with metal objects such as necklaces, hairpins etc.
10. Do not strike or throw the battery against hard surface.
11. Do not directly solder the battery.
12. Do not unpack the battery with a nail or other sharp object.
13. Never disassembling the battery in any way.

Note: The battery can not be placed for a long time under full power and low power. Otherwise, the battery will not be charged or the battery will be wrapped. For long-term storage, please charge the battery to 3.7V and store it in a dry and safe place.



注意：FIREFOX 附带充电器可以安全的给电池充电，建议使用原厂的USB充电器。使用其它充电器有可能将电池充坏导致财产损失！

警告！不仔细阅读下述事项可能导致电池泄露、爆炸或起火：

1. 不能把电池进入水中，长时间不用时把电池放在阴凉和干燥的地方保存。
2. 电池应放在小孩接触不到的地方，如果小孩不小心吞咽电池应立即寻求医疗救济助。
3. 不能在产热源的附近使用或存放电池，比如火源或加热炉。
4. 充电时必需使用符合规格的充电器。
5. 请勿将正负极接反。
6. 请勿将电池直接连接到墙上插座或车载点烟式插座上。
7. 请勿将电池投入火中或给电池加热。
8. 禁止用导线或其它金属物体将电池正负极短路。
9. 禁止将电池与项链、发夹或其它金属物体一起运输或贮存。
10. 禁止撞击、投掷电池，使电池受到硬物撞击。
11. 禁止直接焊接电池端子。
12. 禁止用钉子或其它尖锐物体刺穿电池壳体，禁止锤击或脚踏电池。
13. 禁止以任何方式分解电池。

注意：电池不能在满电和低电状态下长期放置，否则会造成电池不能充电或者电池鼓包，长期放置请将电池充至3.7V电压，并在干燥安全的地方存放。

Helicopter Parameters

FIREFOX

Length	268 mm
Height	80 mm
Weight	52G
Propeller length	249 mm
Tail Rotor blade Diameter	37 mm
Battery Specification	300mAh
Flight time	About 15 min
Main Motor	8520
Tail Motor	0615
Charge time	About 75 min

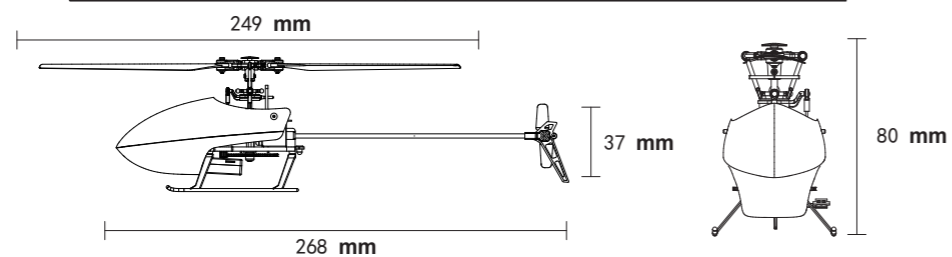

Packaging List

FIREFOX

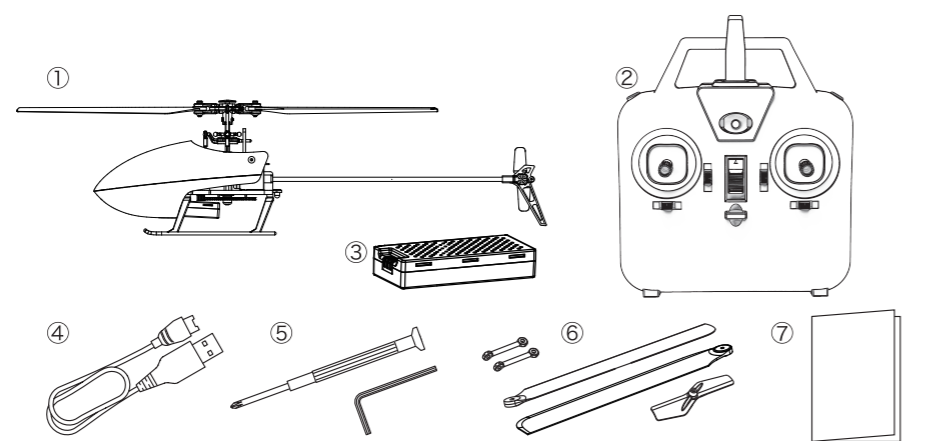

- ① Helicopter ② Remote Control ③ Lipo battery ④ USB charger
 ⑤ Phillips screwdriver+hex wrench ⑥ Upper connecting rod / Propeller / tail rotor ⑦ Instruction manual

3

飞机参数

火狐

长度	268 mm
高度	80 mm
重量	52G
主桨长度	249 mm
尾桨直径	37 mm
电池规格	300mAh
飞行时间	大约15分钟
主马达	8520
尾马达	0615
充电时间	75分钟

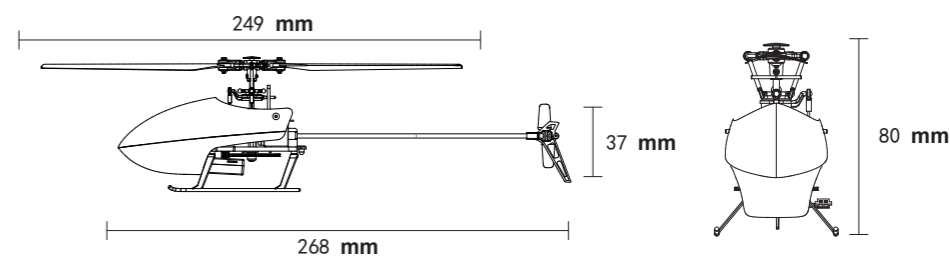

包装清单

火狐

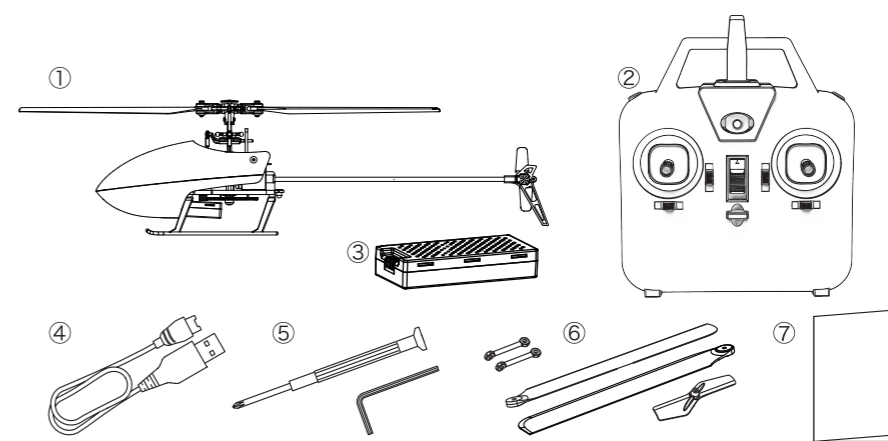

- ① 直升机 ② 遥控器 ③ 锂电池 ④ USB充电器
 ⑤ 十字螺丝刀+六角扳手 ⑥ 上连杆/螺旋桨/尾桨 ⑦ 使用说明书

3

Introduction of transmitter function

FIREFOX

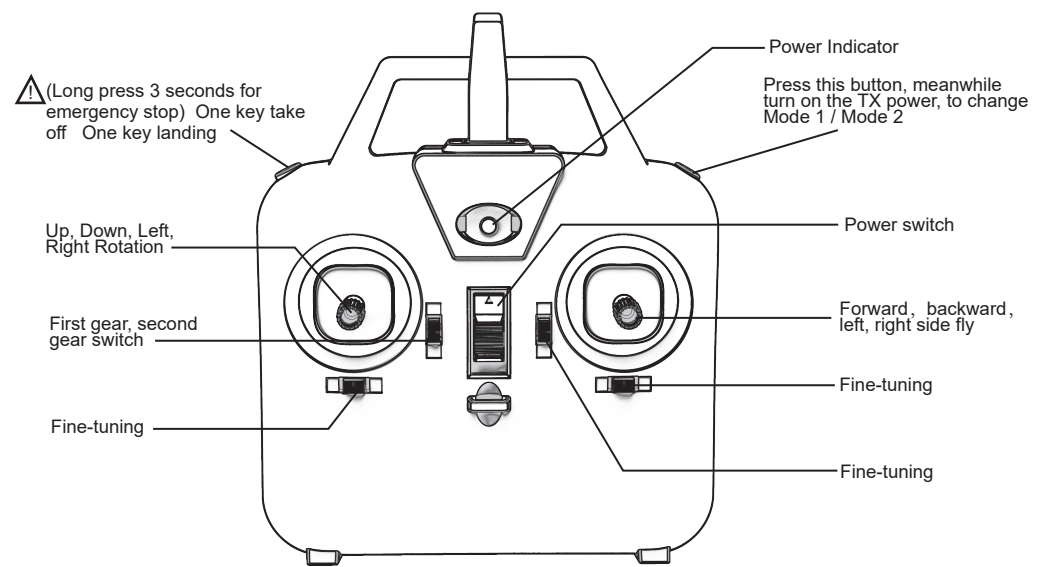

PARTS

FIREFOX

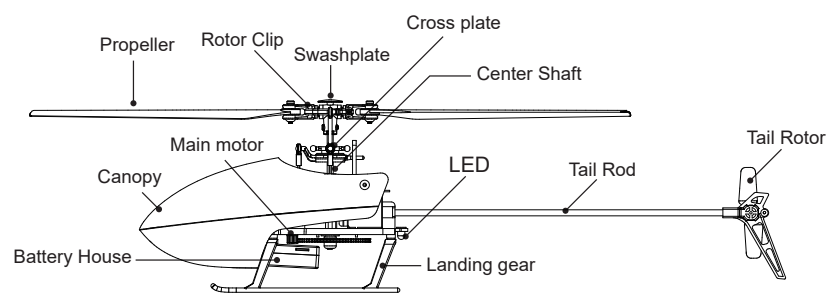

遥控器功能说明

火狐

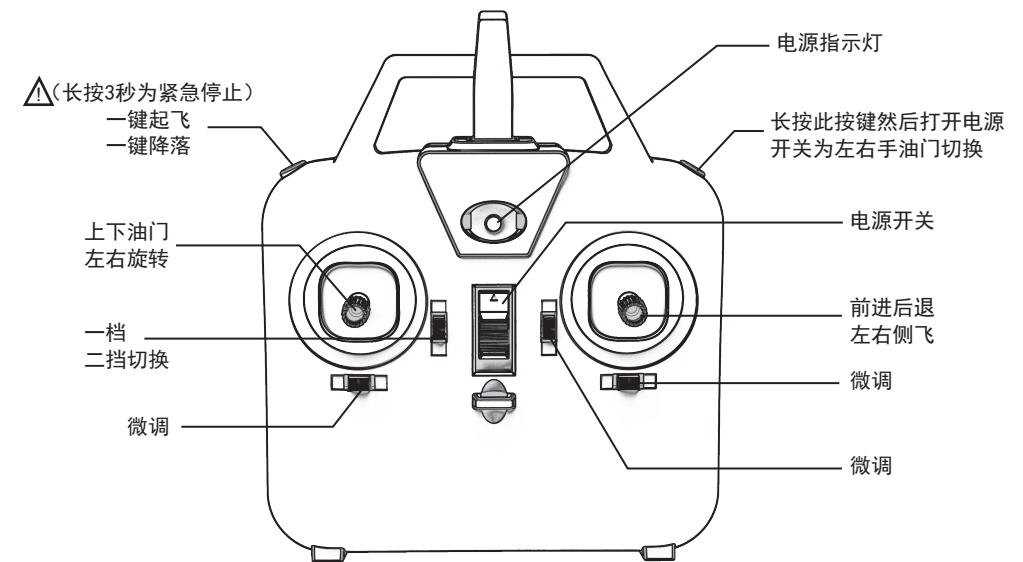

直升机零件名称

火狐

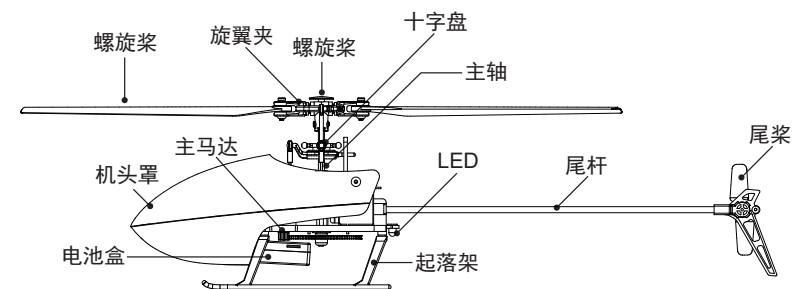

Batteries Charging Method

FIREFOX

Charging method 1

Charging battery by the USB port on a computer.

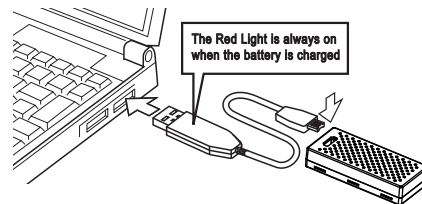

Description:

1. Connect the USB charger with USB port.
2. Connect the battery with USB charger: red light means it is charging, red light out means charging complete.

Charging method 2:Charging battery by power supply adapter.

1. Connect the USB charger with power supply adapter.
2. Connect the battery with USB charger: red light means it is charging, red light out means charging complete.

Charging method 3:Charging battery by power bank

1. Connect the USB charger with power bank .
2. Connect the battery with USB charger: red light means it is charging, red light out means charging complete.

First Flight Preparation CAUTION

FIREFOX

- 1.ensure sufficient power supply of the transmitter and helicopter.
- 2.Keep a flight in a suitable space which away from the traffic, people, electricity pylons and pool.
- 3.Do not lock the main rotor screws too tightly to keep folding smoothly. If the main rotor screws are too tight, the helicopter will shake when flying.
- 4.Under emergency situation, you can press "sharp stop" button for 3" to land the helicopter without rotating.
(Note: this acticon may cause helicopter crash.)

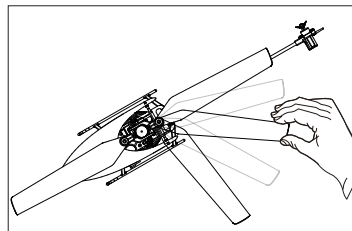

5

电池充电方式

火狐

充电方式1

使用电脑USB端口给电池充电

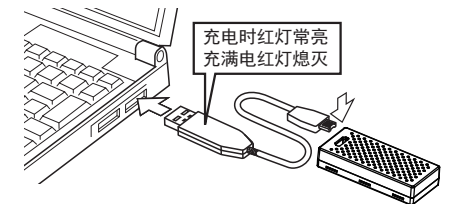

说明:

1. 使用标配的USB充电器与电脑USB端口连接。
2. 将电池连接到充电器，红灯亮表示在充电，红灯熄灭表示已经把电池充满。

充电方式2：使用手机电源适配器给电池充电

1. 使用标配的USB充电器连接手机电源适配器。
2. 将电池连接到USB充电器，红灯常亮表示正在充电，红灯熄灭表示电池已经充满。

充电方式3：使用手机充电宝给电池充电

1. 使用标配的USB充电器连接手机充电宝。
2. 将电池连接到USB充电器，红灯常亮表示正在充电，红灯熄灭表示电池已经充满。

飞前注意事项

火狐

1. 确认遥控器电池电压充足，直升机电池电压充足。
2. 寻找一个合适飞行的场地，远离人群、车、高压电塔、水塘等，方可进行安全愉快的飞行。
3. 主旋翼固定螺丝不可锁过紧，要保持旋翼能顺叠收折，过紧时会造成旋翼无法甩直而产生机体震动。
4. 当飞行中遇到紧急情况无法修正时，可以直接操作“急停”按键，长按急停按键3秒钟，飞机将直接停转落地
(注意：操作此功能有坠落风险)

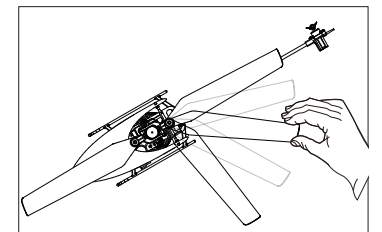

5

Installation method of remote controller battery FIREFOX

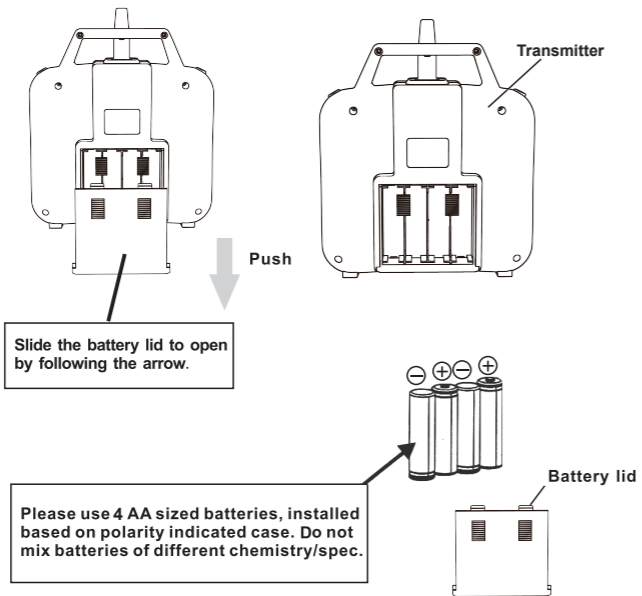

Direction of operation FIREFOX

If you are unfamiliar with the control of the FIREFOX, take time to familiarize it before your first flight.

Throttle

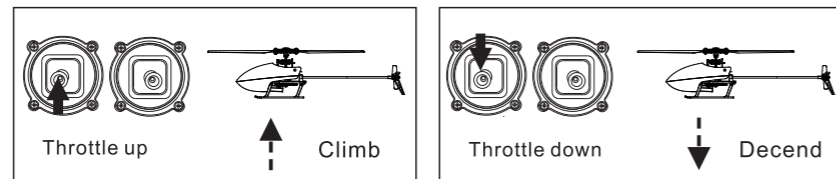

Rudder

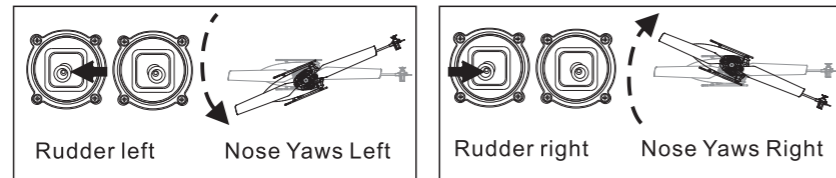

遥控器电池安装方式

火狐

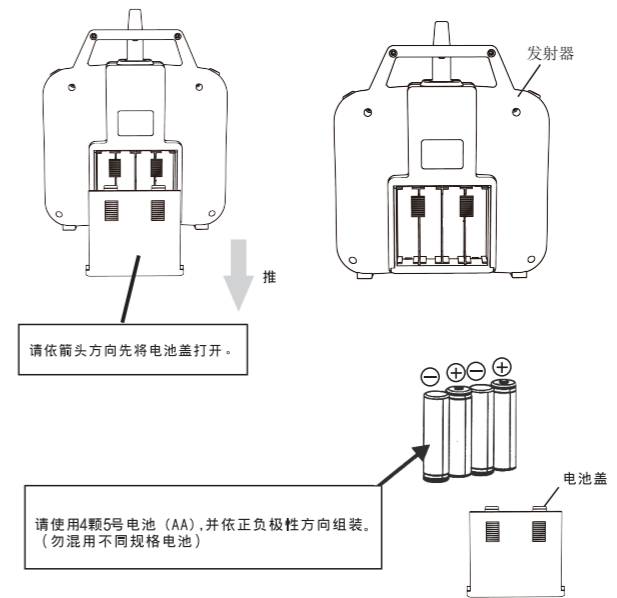

操作方向指导

火狐

如果你不熟悉 FIREFOX 的控制, 花几分钟熟悉它们, 然后尝试你的第一次飞行。

油门

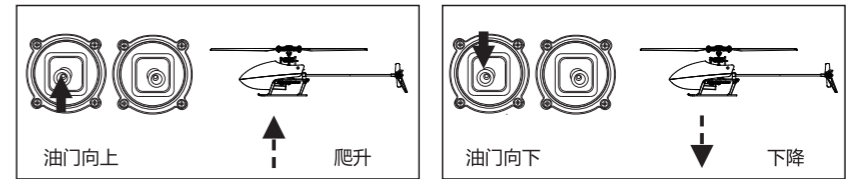

方向

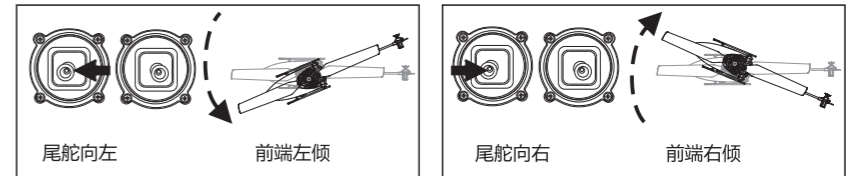

Elevator

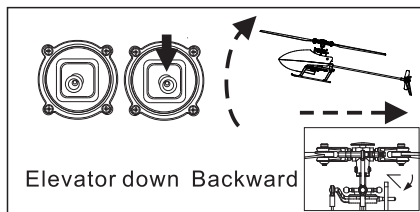
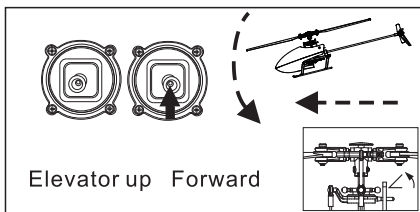

Aileron

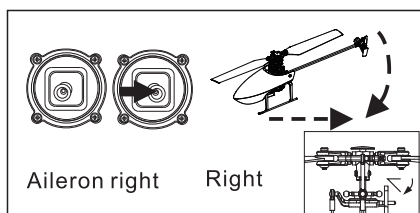
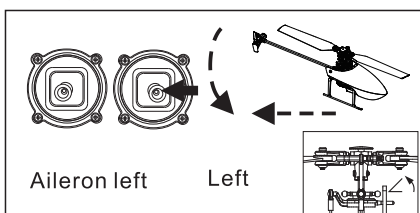

Flight Operation Steps

FIREFOX

1. Turn on the transmitter and let helicopter stay near to transmitter.
2. Connect the battery with helicopter.
3. The lights of the helicopter and the remote control flash at the same time. Then push the throttle stick from top to bottom quickly. The remote control makes a 'DI' sound, and the indicator lights of the helicopter and remote control are always on, which means binding successful.
4. Pull the two joysticks to outer eight angles to start the helicopter. (You can also press the one-key takeoff button to take off the helicopter directly.)
5. Keep the helicopter head forward, and keep safe distance with the helicopter.
6. When manually operating the aircraft to land, please keep the throttle stick at the bottom for 2-3 seconds, and then release it after the propeller has completely stopped rotating. (This operation is not required when using the one-key landing function)

△ Note: 1. In order to avoid hitting, do not look at the helicopter at hip level when it fly.
2. In order to avoid distractions, please confirm without other transmitters at work around.

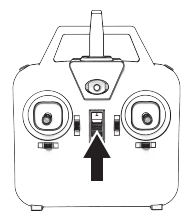

Corresponding to step 1

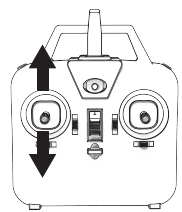

Corresponding to step 3

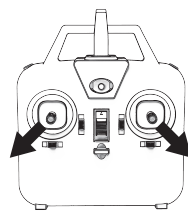

Corresponding to step 4

7

升降

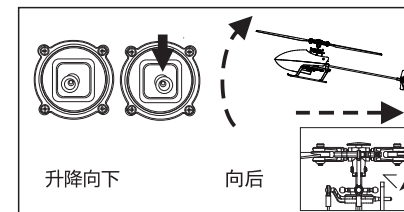
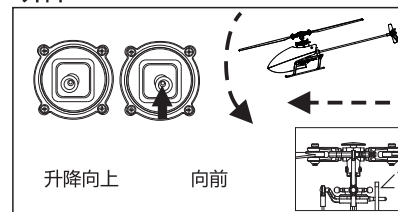

副翼

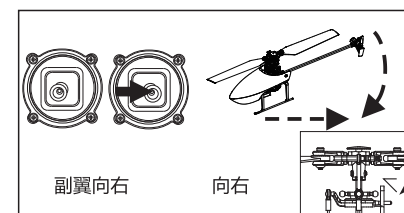
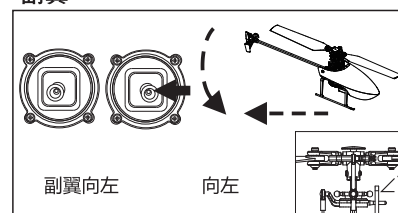

飞行操作步骤

火狐

1. 打开遥控器电源开关。
2. 将飞机电池安全安装到电池仓。
3. 飞机和遥控器灯光同时闪烁，此时将遥控器油门摇杆向上推到底并迅速拉下来，遥控器滴一声响，飞机和遥控器指示灯常亮，对码完成。
4. 将摇杆同时打到外八角度启动飞机。（也可以按一键起飞按键，直接起飞直升机）
5. 保持飞机头部对准前方，与直升机保持安全距离。
6. 当手动操作直升机降落后，请保持油门摇杆向下位置2-3秒钟，等螺旋桨完全停止转动后再松开摇杆。（使用一键降落不需此动作）

△ 注意: 1. 直升机飞起来后，眼睛切勿与直升机平视，以免误伤。
2. 对码时请确定周围没有同一型号遥控器打开，以免影响对码。

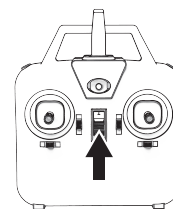

对应步骤1

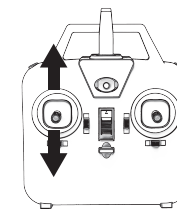

对应步骤3

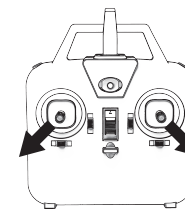

对应步骤4

7

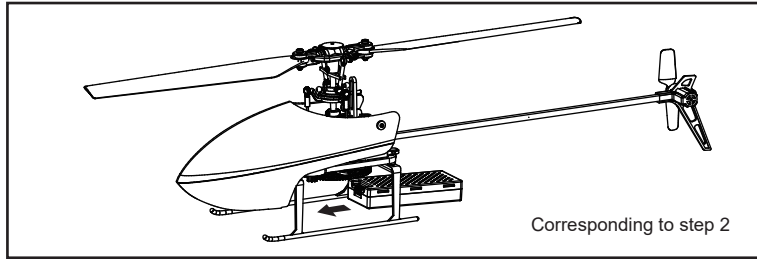

Note: Beginner should pay attention to the direction of flight. Keep the head forward to avoid causing injury .

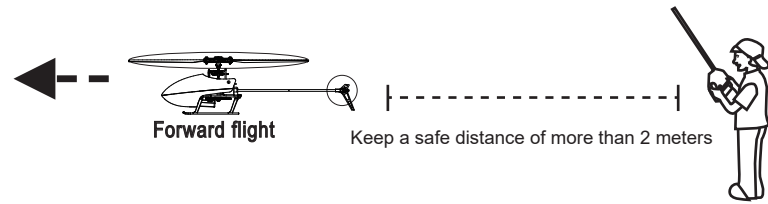

Flight Yaw correction method

FIREFOX

Press the trimming button when helicopter has yaw problems.

The helicopter has set up hovering. If you are dissatisfied with hovering or the helicopter have a yaw, please follow these steps to adjust.

Take off with the throttle joystick. According the direction of yaw, press the fine-tuning button in the opposite direction until the plane hovering.

Forward/ backward Yaw			Fine-tune according to the direction of the arrow
Left/right Yaw			Fine-tune according to the direction of the arrow
Side fly Yaw			Fine-tune according to the direction of the arrow

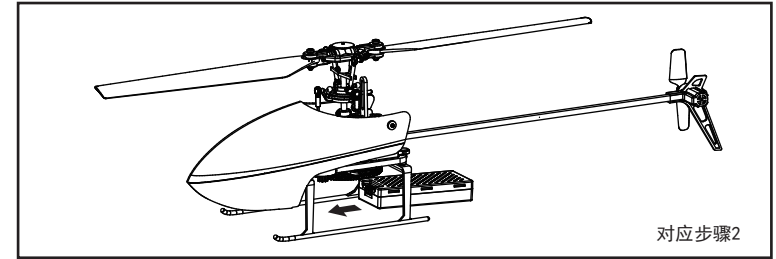

注意：初学者请注意飞行方向，尽量保证飞机头部对准前方，以免操作失误造成损伤！

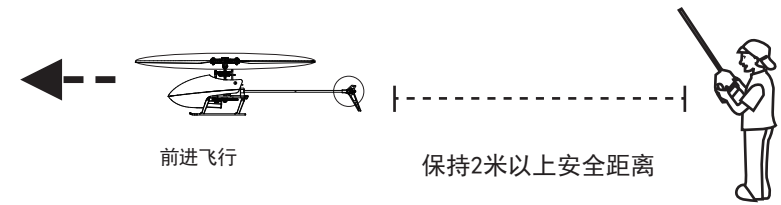

飞行偏航修正方法

火狐

如果飞行出现偏航，可通过直接拨动微调按键修正。

你所购买的产品出厂时已经设定完成，如果你对飞机悬停不满意或飞机还是存在偏航，你可以通过以下设定，来调整飞机悬停。

控制油门飞机起飞，根据目前飞机的偏航方向，向反方向拨动微调按键，至到飞机能够平稳悬停

直升机 前后偏航			按照箭头指示方向调整微调
直升机左右 方向偏航			按照箭头指示方向调整微调
直升机 侧飞偏航			按照箭头指示方向调整微调

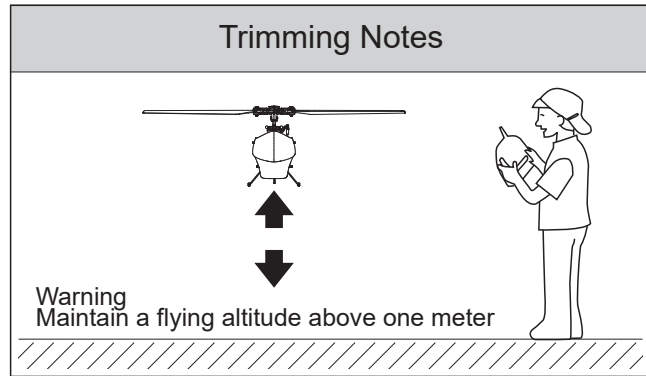

Introduction of the corresponding socket of receiver

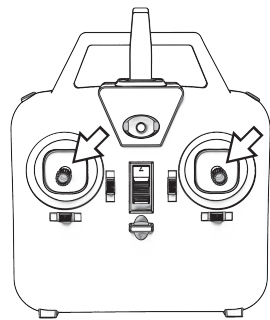
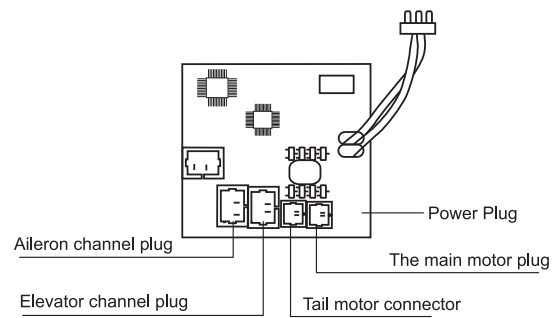

Gyro calibration method

1. When flying yaw, first land and calibrate the gyroscope.
2. When calibrating the gyroscope, the aircraft must be placed on a level ground.
3. The indicator light will flash quickly during the calibration process, the indicator light stops flashing to take off.

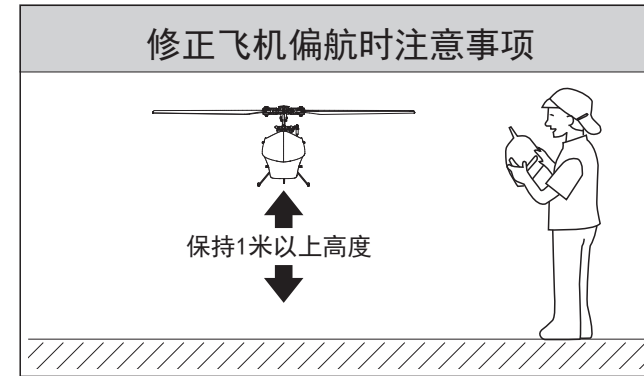

接收机对应插座介绍

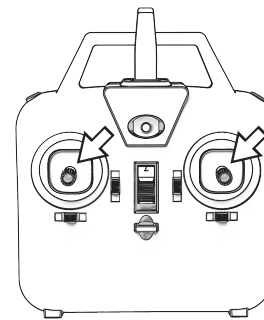
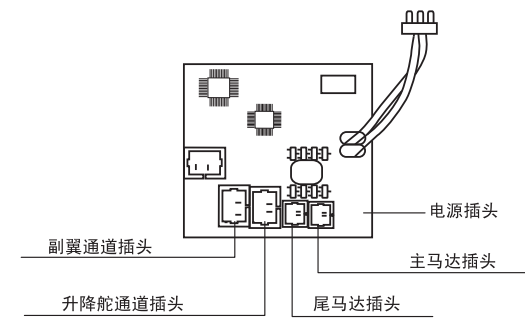

陀螺仪校准方式

1. 当飞行偏航时，可以先尝试先将飞机降落校准陀螺仪。
2. 校准陀螺仪时需将飞机放置水平地面不能偏斜。
3. 当校准时指示灯快速闪烁，校准完成指示灯常亮，然后再起飞。

Parts replacement instructions

FIREFOX

Remove the propeller with a hex wrench.
Be careful not to be too tight when installing
the new propeller

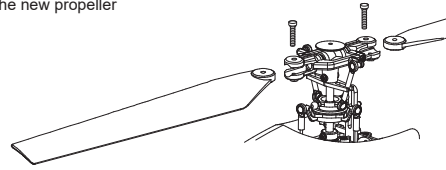

When replacing the tail rod, pull the plug backwards
forcefully, pay attention to the direction when installing,
and align the power cord with the hole.

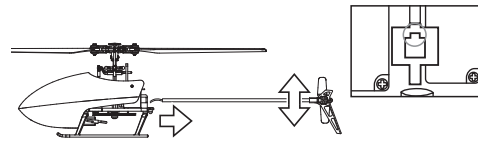

Unplug the plug, then twist the motor
left and right to pull out

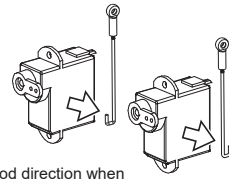
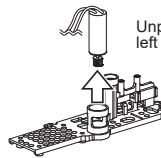

Pay attention to the connecting rod direction when
disassembling and replacing the servo, as shown:

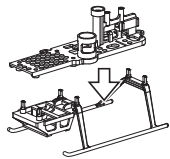

Pull out the landing gear downwards,
and press the corresponding holes when installing.

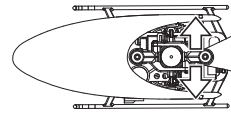

When replacing the receiver, remove the double-sided tape together,
align the new receiver with the edge of the rack and stick it tightly
without skewing, and then connect the servo and the motor in the order of the plugs.

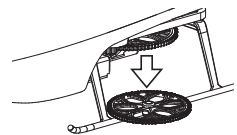
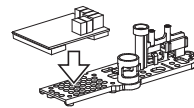

Pull out the big gear straight down, pay attention to the
direction when installing the new gear, and the axis plane
should be aligned with the plane of the inner hole of the gear.

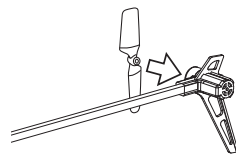

When removing and replacing the tail rotor, please
pay attention to the direction, align the motor shaft
and press it slowly to ensure smooth rotation.

10

零部件更换指示

火狐

用六角扳手将螺旋桨拆下，
安装新的螺旋桨时注意不能太紧

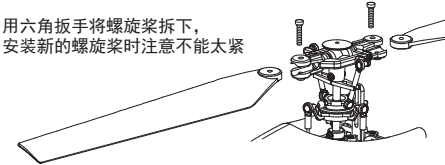

更换尾杆是，先将微视插头拔下，向后用力拔出，
安装时注意方向，电源线要对准孔位

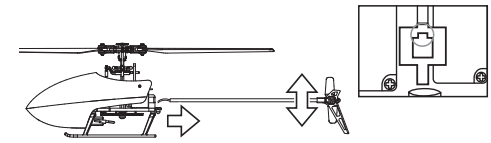

先将插头拔掉，
将电机左右扭动向上拔出

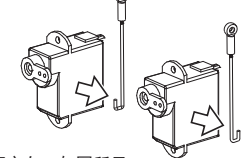
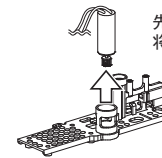
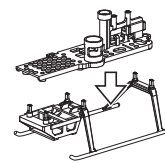

拆换舵机时注意连杆方向，如图所示：

将起落架向下拔出，安装时配合
对应孔位并压紧

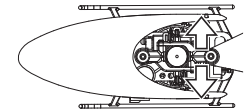

当更换接收机时，请将双面胶一同拿掉，将新的接收机
对齐机架边缘粘紧，不要偏斜，然后按照插头顺序连接
好舵机和马达

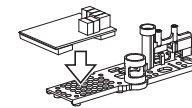
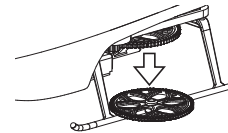

将大齿轮向下直接拔出，安装新齿轮时注意方向，
轴平面要与齿轮内孔平面对准。

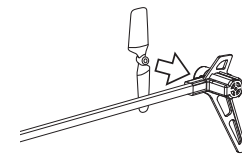

拆换尾桨时请注意方向，对准马达轴慢慢压紧，
保证转动顺畅。

10

Abnormal Problem Solving Method

FIREFOX

	Problem	Possible Cause	Solution
1	Connect the battery with helicopter, then the signal light keeps flashing and without response when operate.	The helicopter without bind with the transmitter.	Bind the transmitter again
2	The helicopter without any response when you connect the battery.	Check the power supply of helicopter and transmitter; Check the battery's voltage of the helicopter and transmitter; Batteries had a poor connecting.	Check the installation site of Transmitter's batteries; Use full voltage batteries; Install the batteries again; Confirm the batteries have a good connecting.
3	Push the throttle but the motor not at work, the receiver's signal light keep flashing	Helicopter's battery has a low voltage; The lipo battery has a poor connecting.	Charge the battery or change a full charge battery; Connect the battery with receiver again.
4	Turn on the helicopter after bind, the main blade can rotate but the helicopter can not take off	Helicopter has a low voltage; The main shaft and the gear may loose.	Charge the battery or change a full charge battery; Press the main shaft and gear tightly
5	The helicopter is violently shaking	Main rotor deformed cross shaft bent tail rotor bent Blade clamp screws are too tight to cause the main blade can not rotate	Change the main blade; Change the cross shaft; Change tail rotor; Loose the blade clamp screw.
6	Helicopter spinning to left after take off.	Tail motor has a poor power; The blades loose; Tail motor was broken.	Check the connection of tail blade and motor shaft. if loose, change tail blade or tail motor.
7	The helicopter has a little yaw:	made a operational error of the trimming button	1.According to its yaw direction, push the trimming button in the opposite direction; 2.Reset the hovering point.
8	The helicopter has a serious yaw.		Check the servo if work properly; Check the swash plate; Check the rod sticks if loosing.

异常问题解决方法

火狐

	状况	原因	对策
1	电池与接收机连接后,接收机提示灯持续闪烁,操作无反应。	发射机与接收机对码失败。	请重新执行发射机与接收机对码
2	电池与接收机连接后,直升机没有任何反应。	检查发射机与接收机是否接通电源; 检查发射机与接收机电池电压。	打开发射机,确认电池安装位置; 使用完全充电的电池;重新插入电池。
3	推动油门摇杆时,马达不转,且接收机提示灯开始闪烁。	直升机电池电压不足。	将电池充电或更换一个充满电的电池。
4	对码成功后,启动直升机,主桨有持续转动,但不能飞。	直升机电池电压不足主轴齿轮松开。	将电池充电或更换一个充满电的电池,将主轴与齿轮压紧。
5	直升机震动的很厉害。	主桨变形,横轴弯曲,尾桨变形, 桨夹螺丝锁太紧,导致主桨不动。	更换主桨, 更换横轴, 更换尾桨, 将桨夹螺丝适当拧松。
6	直升机起飞向左打转。	尾马达力量不足 桨叶松动 尾马达损坏	检查尾桨叶与马达轴的配合, 如果松动更换尾桨叶。马达损坏 更换尾马达。
7	起飞后飞机出现轻微偏航:	误操作微调键	1. 向偏航方向打微调,只到修正为止 2. 重新设置悬停
8	起飞后飞机出现严重偏航		1. 检查舵机是否工作正常 2. 检查十字盘是否正常 3. 检查连杆是否掉落